

Check Valve, piloted NG 4 ISO 4401 sandwich-plate

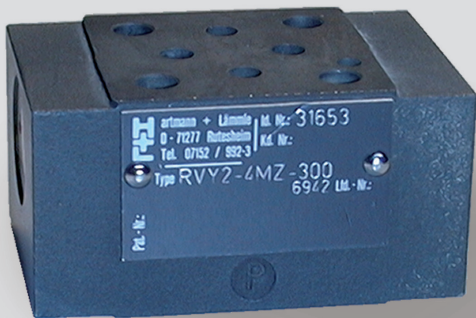

- hermetically closed seat valve
- compact design
- soft switch with forebalancing

Technical Data

General

Configuration number	please see symbol diagram
Type of valve	seat valve, spring-weight
Mounting method	sandwich plate
Mounting positions	mountable in any positions
Ambient temperature	-5 to +50 °C
Mass valve	0.4 kg

Hydraulic

Operation pressure max.	315 bar
Hydraulic oil temperature	-5 to +70 °C
Viscosity range	10 to 300 mm ² /s
max. flow	see characteristic curve
Control ratio	3,3:1

Characteristic curve

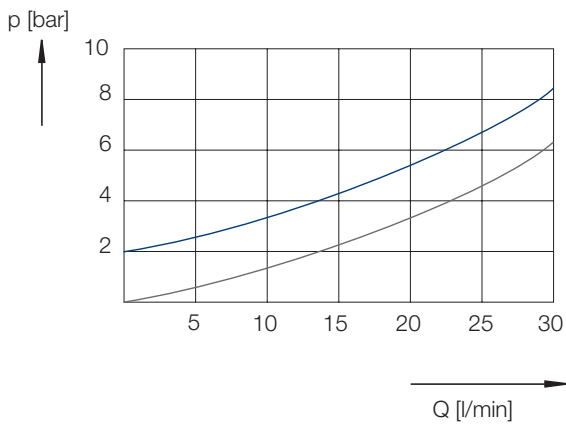

— 2 → 1

— 1 → 2

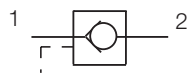

for hydraulic oil 35 mm²/s, 50°C

Symbol

RVY

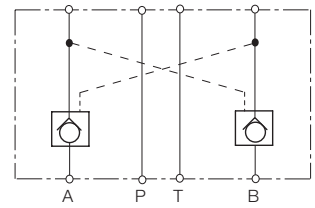

Dimensional Drawing

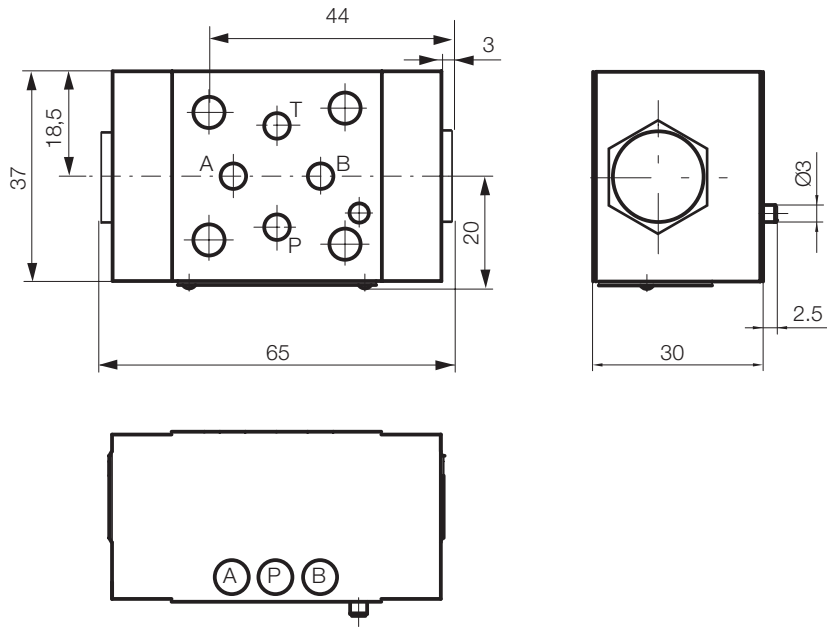

all dimensions in mm

Port Connection Pattern NG 4 ISO 4401

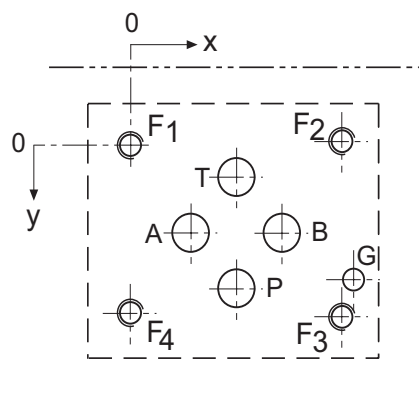

view: fastening side of mounting plate

	P	A	T	B	F1	F2	F3	F4	G
Ø max [mm]	4.5	4.5	4.5	4.5	-	-	-	-	3.4
x [mm]	12	4.3	12	19.7	0	24	24	0	26.5
y [mm]	20.25	11.25	2.25	11.25	0	-0.75	23.25	22.5	17.75

F: M5, thread depth min. 1.5 x Ø

G: bore hole depth min. 1.5 x Ø

Single-Unit Mounting Plate

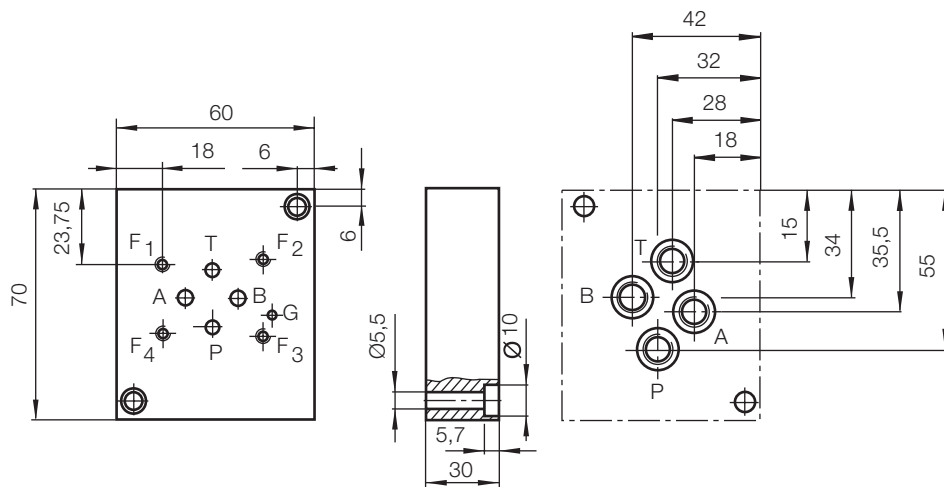

Order number single-unit mounting plate:

PW4M-G1-400, pipe connections R1/8"

PW4M-G2-400, pipe connections R1/4"

Multiple-unit mounting plate on request.

Type Code

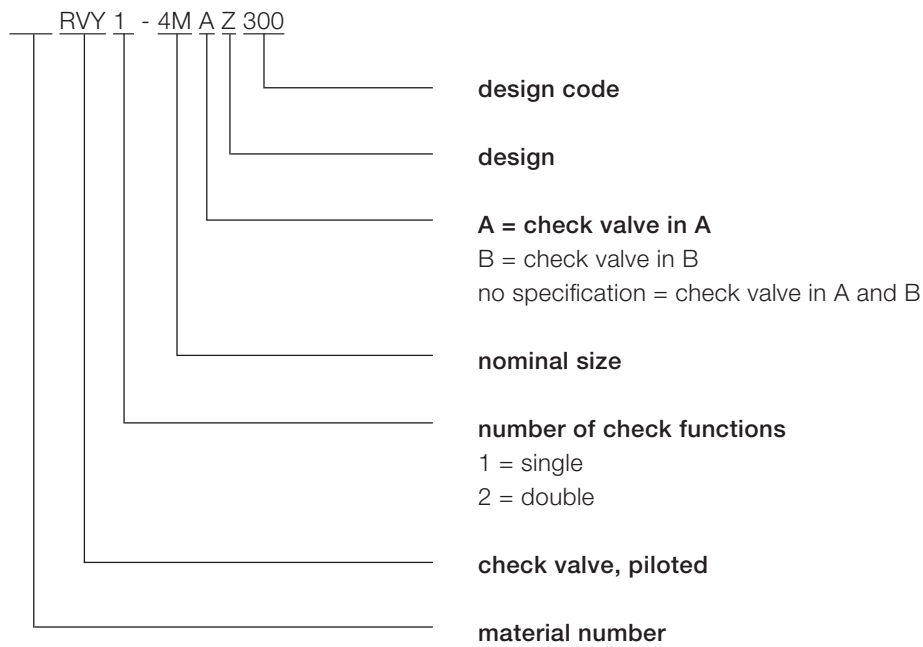

Voith Turbo H + L Hydraulic GmbH & Co. KG
Schuckertstraße 15
71277 Rutesheim, Germany
Tel. +49 7152 992-3
Fax +49 7152 992-400
sales-rut@voith.com

voith.com



VOITH
Engineered Reliability